

Transmit and Receive Modules for Antenna Measurements up to 500 GHz

J. Hartmann¹, J. Habersack¹, H.-J. Steiner¹, J. Lemanczyk², P. De Maagt²

¹ EADS Astrium
Equipment and Subsystems, SM74 - Antenna Measurement Engineering
81663 Munich, Germany
Phone: +49 89 / 607 - 22420 Fax: +49 89 / 607 - 25538
E-mail: juergen.hartmann@astrium-space.com

² ESA/ESTEC, Electromagnetics Division
P.O.Box 299, 2200 AZ Noordwijk, The Netherlands
Phone: +31 71 / 565 - 4402 Fax: +31 71 / 565 - 4999
E-mail: jlemancz@estec.esa.nl

Abstract

Future scientific and earth observation instruments as MASTER, PLANCK and HERSCHEL of ESA/ESTEC are working in the sub-millimeter wave range. For measurement of the instruments, a study named ADMIRALS was performed, mainly to identify the most suitable test facility, procure transmit and receive modules and perform measurements up to 500 GHz.

The CCR 75/60 of Astrium GmbH, Ottobrunn, was selected for the facility calibration and the pattern verification with an Representative Test Object (RTO). The measurements were performed in three different frequency bands between 200 and 500 GHz. The mm-wave transmit and receive modules were designed, manufactured and tested by Radiometer Physics GmbH (RPG), Meckenheim. A cost efficient design was achieved by a modular concept.

Within this paper, the design and realization of the modules as well as most characteristic performance parameter will be presented.

1 Introduction

For the measurement of future earth observation and limb sounder missions e.g. MASTER, PLANCK and HERSCHEL of ESA/ESTEC [1], which are working in the frequency range at least up to 500 GHz, measurement equipment was designed and manufactured. The operating frequency range up to sub-mm wave frequencies in combination with the large aperture sizes of the related antennas represents a main challenge towards measurement technology for the instruments.

Within the study ADMIRALS for ESA/ESTEC, the Compensated Compact Range CCR 75/60 of Astrium GmbH was selected for testing the instruments [2], according to the existing highly accurate status, the already performed qualification up to 200 GHz [3] and the large size of its quiet zone. Further, applicable transmit and receive modules for discrete frequency bands at 203, 322 and 503 GHz were designed, manufactured and tested by Radiometer Physics GmbH. The bandwidth of the modules is between 1.3 and 4 %.

In the following, the requirements of the transmit and receive modules for antenna tests up to 500 GHz are described. The design of the modules as well as characteristic test data will be presented.

2 Requirements

The requirements of mm-wave transmit and receive modules towards transmit power and receive sensitivity are oriented to the power levels, calculated in the link budget of the CCR, given in Table 1. Within the link budget, the antenna aperture size of 1.5 m in diameter of the single offset paraboloid, which is used as Representative Test Object (RTO), is considered.

Freq. [GHz]	Free Space Loss [dB]	Gain CCR Feed [dBi]	Gain Test Ant. [dBi]	Rec. Power Level [dBm]	Dyn. [dB]	Rec. Sens. [dBm]
203	103.7	20	66.1	- 17.6	90	- 108
322	107.7	20	70.0	- 17.7	80	- 98
503	111.6	20	73.8	- 17.8	70	- 88

Table 1 Link Budget for CCR 75/60 of Astrium GmbH (Reflector Size of RTO for Gain Value of Test Antenna Considered; Transmit Power of 0 dBm Assumed)

The related measurement setup [4] for antenna tests in the CCR 75/60 of Astrium GmbH up to the mm-wave frequency range is shown in Figure 1.

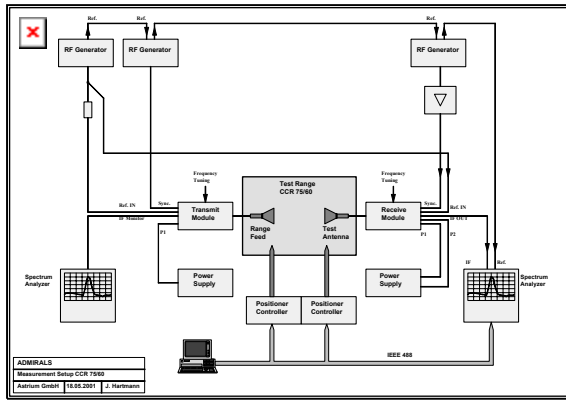

Figure 1 Test Setup for Measurements up to 500 GHz in the CCR 75/60

For the transmit modules, mainly the output power, which should be in the order of 0 dBm or higher is a main design parameter. Further, a low amplitude taper and low cross-polarization contribution has to be considered within the design of the feed horn antenna. For the receive modules, a low sensitivity level, which is correlated to a low input noise temperature is a main design parameter. Further, the mixing concept and subsequently the mixer conversion loss value (L_M) are important. The relation between sensitivity (S) and input noise temperature (T) is as follows:

$$S = k_B \cdot T \cdot \Delta f + S/N_{\text{MIN}} + L_M \quad (1)$$

For minimum detectable signals, a signal to noise ratio (S/N_{MIN}) of typical 12 dB is assumed. Within (1), k_B represents the Boltzmann constant.

3 Transmit Modules

The basic concept of the transmit module for the three frequency bands is shown in Figure 2.

For reduction of costs, the design is based on one single source unit (Gunn-Oscillator with PLL), if possible, and interchangeable multiplier/feed sections. According to the frequency range locations, one source unit in the frequency range between 99 and 109 GHz and one source unit in the frequency range between 83 and 84.2 GHz has to be used. The source units contain the PLL (Phase Locked Loop) module, the Gunn-Oscillator with isolator and coupler as well as harmonic mixer and IF amplifier. For the IF a frequency at 100 MHz was selected.

The applied Gunn-Oscillator is controlled by the PLL module, Model 800 A from XL Microwave. For reference signal an external 100 MHz signal is used. According to harmonic mixing on the eleventh harmonic for the 203 and 322 GHz module and on the ninth harmonic for the 503 GHz module, respectively, the LO frequency is in the range between 8.8 and 9.8 GHz. Subsequent multiplier are used to achieve the required RF output frequencies.

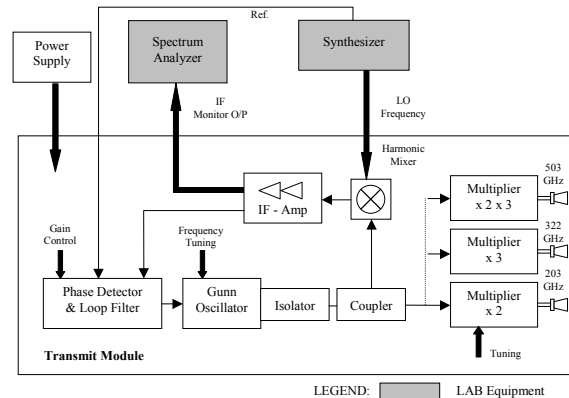

Figure 2 Concept of Transmit Module for 203, 322 and 503 GHz

For realization of a modular concept, the source unit is mounted on a separate platform on the basis mounting structure, as shown in Figure 3. Further, also the feed/multiplier unit is separately fixed on the mounting structure, whereas for all frequency bands, the phase center is maintained at the same position. The mounting structure can be fixed and aligned on the polarization positioner of the CCR with phase center of the feeds positioned at the phase center of the facility.

For the feed, a corrugated horn is applied, in order to get a frequency independent constant and low amplitude and phase taper within the FoV (Field of View) or subreflector illumination range, respectively. Further, also a low cross-polarization contribution below -40 dB within the FoV can be achieved. A picture of the 503 GHz transmit module is shown in Figure 3.

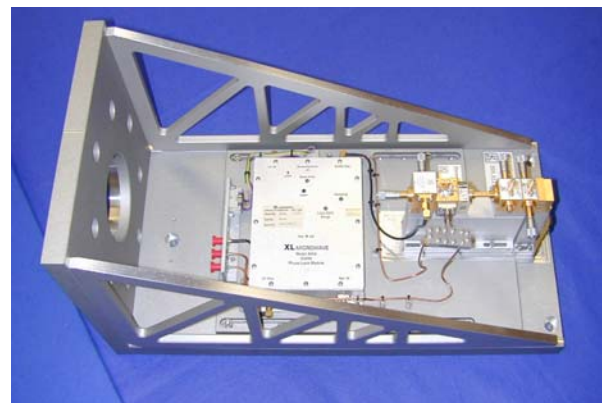

Figure 3 503 GHz Transmit Module mounted on Basis Mounting Structure

4 Receive Modules

The concept of the receive module is shown in Figure 4. Mainly, it consists out of a Quasi-Optical-Network (QON) for each frequency band, a local oscillator (LO) unit and a fundamental mixer. All components are mounted on the optics plate of the QON.

The LO unit of the receive module and the LO unit of the transmit module are electrically as well as mechanically identical and both units can be interchanged. A difference exists only in the type of the feed horn. The feed horn of the transmit module is adapted w.r.t. optimum illumination of the CCR subreflector and the feed horn of the receive module LO unit is adapted w.r.t. optimum illumination of the related mirror in the QON.

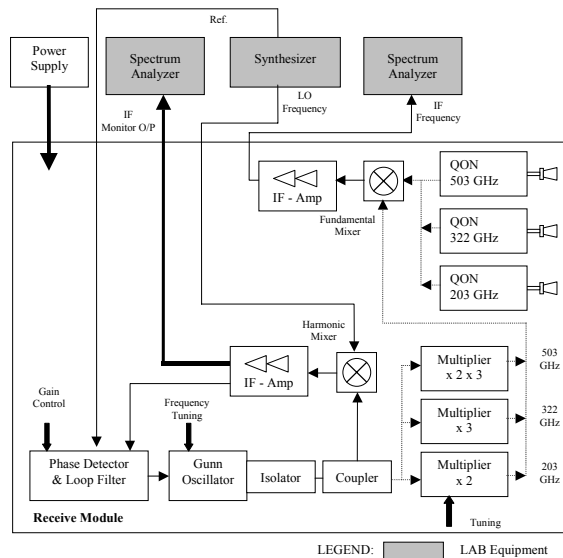

Figure 4 Concept of Receive Module for 203, 322 and 503 GHz

The adjustment of the interferometer w.r.t. wavelength of the IF signal is performed via longitudinal movement of a mirror. The IF output is defined with 3.5 GHz and the distance between minimum and maximum output signal level is therefore 43 mm. In order to achieve a low mixer conversion loss and a high sensitivity, the fundamental mixing principle is applied.

The IF signal is subsequently amplified by a narrow band LNA (Low Noise Amplifier), whereas the 1 dB compression point of the output power is at +14 dBm. A picture of the receive module is shown in Figure 5.

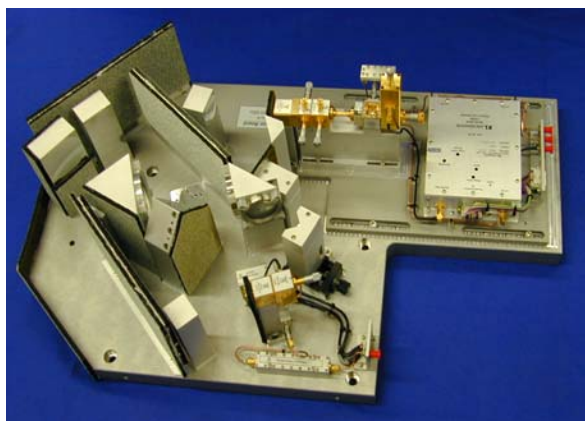

Figure 5 500 GHz Receive Module

5 Measurement Results

For verification of the module performance, the parameters frequency range, power, stability and antenna pattern were tested for each frequency band for the transmit modules. For the receive modules additionally the sensitivity and the conversion loss were tested.

The output power and also frequency range were measured with a power meter by variation of the frequency. For that aim, the TK (Thomas Keating) THz power meter was used. The TK THz power meter uses a photo acoustic detector with a closed air-cell and a pressure transducer within the power head. The frequency range is up to 3 THz. The sensitive area at the power head is in the order of 30 mm in diameter and the typical NEP (Noise Equivalent Power) is $5 \mu\text{W}/\sqrt{\text{Hz}}$. A summary of the measurement results is given in Table 2.

For stability test of the modules, the antenna test setup, given in Figure 1, was used with the antenna oriented in boresight direction. The measurements were performed over a time period of at least 5 minutes, in order to get no related degradations during the time period of pattern measurements.

The stability test resulted in a maximum drift values of 0.06 dB/hour for the output power of the IF signal at the receive module. This value comprises the transmit and receive modules for each frequency band. A variation in frequency could not be identified for the modules because of additional frequency drift of the laboratory equipment, as spectrum analyzer and RF generator.

		203 GHz	322 GHz	503 GHz
Freq.	[GHz]	196 .. 207	315 .. 327	495 .. 505
Power	[dBm]	+7.0..+8.5	+2.6..+5.4	-3.0..-1.9
Gain**	[dBi]	14.4	14.4	14.4
Taper*	[dB]	-1.2	-1.2	-1.2
X-Pol.*	[dB]	< -40	< -40	< -40

* Within FoV of ± 12 degree

** Calculated Directivity Value with no Losses Assumed

Table 2 Characteristic Data of Transmit Module

The summarized results for the transmit modules are given in Table 2 for each frequency band, whereas the gain values correspond to calculated directivity values with no additional losses assumed.

For the receive module, the frequency range was determined by combined measurements with the transmit module and variation of the transmit frequency. The sensitivity of the receive modules was indirectly measured by measuring the input noise temperature by using standard hot/cold Y-factor measurement. For that aim, the receiver input is terminated with a black body (e.g. an absorber) at ambient temperature and at liquid nitrogen temperature. The system temperature T_{sys} can be calculated out of (2):

$$Y = \frac{P_h}{P_c} = \frac{T_{sys} + T_h}{T_{sys} + T_c} \Leftrightarrow T_{sys} = \frac{T_h - YT_c}{Y - 1} \quad (2)$$

whereas T_h and T_c are the ambient and liquid nitrogen temperatures, respectively, and P_h and P_c are the related output power levels, which are measured. The sensitivity can be calculated as given in (1).

The conversion loss of the receive module contains the loss of the QON and the mixer conversion loss. The QON loss values are determined heuristically according to the experiences of RPG and the mixer conversion loss values can be calculated out of hot/cold measurements, applied to the IF signal chain. Within these measurements, a 50Ω termination is used instead of the black body. The mixer conversion loss (L) can be calculated out of (3):

$$L = \frac{P_{hif} - P_{cif}}{P_h - P_c} \quad (3)$$

with P_{hif} and P_{cif} are the measured power levels of the IF output signal for hot and cold temperature, respectively. A summary of the most important data of the receive modules is given in Table 3.

	203 GHz	322 GHz	503 GHz
Inp. Freq. [GHz]	199 .. 207	318 .. 326	498 .. 505
Inp. Power [dBm]	< -10	< -10	< -10
Inp. Temp. [K]	2400	3300	2900
Sensitivity [dBm]	-113	-112	-112
QON Loss [dB]	0.04	0.06	0.08
Mixer Loss [dB]	8.3	8.2	8.0
IF Freq. [GHz]	3.5	3.5	3.5
IF Power [dBm]	0..+10	0..+10	0..+10
Gain** [dBi]	23.8	23.0	23.0
Taper* [dB]	-1.2	-1.2	-1.2
X-Pol.* [dB]	< -40	< -40	< -40

* Within FoV of ± 15 degree

** Calculated Directivity Value with no Losses Assumed

Table 3 Characteristic Data of Receive Module

The antenna pattern of the receive module was measured in similar way as performed with the transmit module. For the receive case, the transmitter was fixed and the receive module was rotated.

6 Conclusions

For measurement of sub-mm wave space applications in the CCR 75/60 of Astrium GmbH, transmit and receive modules were designed and manufactured. The modules are working within discrete frequency bands at 203, 322 and 503 GHz.

Within this paper, the test set-up as well as measurement results concerning characteristic data of

the modules, manufactured at RPG, are described. Requirements have to be fulfilled w.r.t. power level, dynamic range and sensitivity values related to the CCR link budget. Further, also CCR oriented pattern data had to be fulfilled. For the test antenna, an offset reflector antenna with a reflector size of 1.5 m in diameter was applied.

The results exhibited a good performance of the transmit module w.r.t. output power levels of -3 dBm @ 503 GHz up to +8.5 dBm @ 203 GHz with very high stability. For the receiver, sensitivity values in the order of -112 dBm for all frequency bands could be measured. The required pattern characteristics w.r.t. amplitude taper in the order of -1.2 dB in the FoV and cross-polarization below -40 dB were also completely fulfilled.

The application of sub-mm wave transmit and receive modules for highly accurate measurements up to 500 GHz in the CCR 75/60 of Astrium GmbH was demonstrated. The applied modules of RPG exhibited excellent performance characteristics, whereas also cost efficiency and reliability was realized by a modular design concept.

7 References

- [1] P. de Maagt, G. Crone: (Sub)Millimetre Wave Antenna Technology for Upcoming ESA Missions, *AP2000 Millennium Conference on Antennas & Propagation*, Davos, Switzerland, April 2000
- [2] J. Habersack, J. Hartmann, J. Lemanczyk, P. de Maagt, H.-J. Steiner: Facility Trade-off for Measurements up to 500 GHz, *Proc. 22nd AMTA*, Philadelphia, USA, October 2000
- [3] J. Habersack, W. Lindemer, H.-J. Steiner: Sensor Measurements up to 200 GHz in the Compensated Compact Range with Broadband Transmit and Receive Modules, *Proc. 19th AMTA*, Boston, USA, October 1997
- [4] J. Hartmann, J. Habersack, H.-J. Steiner, J. Lemanczyk, P. de Maagt: Calibration and Verification Measurements in Compensated Compact Ranges up to 500 GHz, *Proc. 23rd AMTA*, Denver, USA, October 2001
- [5] J. Hartmann, J. Habersack, H.-J. Steiner: Transmit and Receive Modules for Measurement of Future Space Applications in the Terahertz Frequency Range, *Proc. AMTA 2001, 23rd AMTA Symposium*, Denver, USA, 22. – 26. October 2001