

## FACILITY TRADE-OFF FOR MEASUREMENTS UP TO 500 GHZ

*J. Habersack<sup>1</sup>, J. Hartmann<sup>1</sup>, J. Lemanczyk<sup>2</sup>, P. De Maagt<sup>2</sup>, H.-J. Steiner<sup>1</sup>*

<sup>1</sup> Astrium GmbH, DaimlerChrysler Aerospace  
Antennas & Payload Components, TP53, 81663 Munich, Germany  
Phone: +49 89 / 607 -22420 Fax: +49 89 / 607 - 25505  
E-mail: juergen.hartmann@astrium-space.com

<sup>2</sup> ESA/ESTEC, Electromagnetics Division  
P.O. Box 299, 2200 AZ Noordwijk, The Netherlands  
Phone: +31 71 / 565 - 4402 Fax: +31 71 / 565 - 4999  
E-mail: jlemancz@estec.esa.nl

### Abstract

Future European Space Agency (ESA) earth observation and space science missions such as MASTER and PLANCK will have instruments and associated antennas working well up into the Terahertz frequencies. The large sizes of the antenna apertures and the need to accurately verify their performance, place high demands on test facilities and test techniques. In recent decades, different types of facilities have been developed. ESA has identified that for measurements up to at least 500 GHz, existing facilities and techniques could be applied with a relatively modest investment. A trade-off between the cylindrical near-field and compact antenna test ranges at Astrium has been carried out to identify which of the two existing ranges would provide better accuracy.

#### Keywords:

*mm-Wave Antenna Measurements, Compact Ranges, Near Field Measurements*

### 1. Introduction

Future ESA earth observation missions (MASTER) or astronomy missions (PLANCK) are planned with high resolution, high sensitivity and high frequencies of operation. MASTER is a limb sounder which operates in the frequency range 200 - 500 GHz. PLANCK will have two instruments sharing one large aperture antenna; the Low Frequency Instrument, 30 - 100 GHz, and the High Frequency Instrument, 100 - 857 GHz [1].

The required elevation resolution of the MASTER instrument for investigations of upper atmosphere chemistry, calls for a very narrow beam in elevation while it is not so critical in azimuth. The dimensions of the

MASTER offset cassegrain main reflector are 2.2 m x 0.8 m [1] and can be seen in figure 1.

In contrast to previous mm-wave antennas with relatively small dimensions, the electrically large aperture place extreme demands on available measurement techniques and the test facilities where these antennas have to be measured. In this paper, a trade-off between the existing antenna test facilities at Astrium, which could fulfill the required measurement accuracy [14] up to at least 500 GHz, will be presented. Each facility's specific characteristics and its technical as well as economic advantages and disadvantages for application in the upper frequency ranges will be outlined.

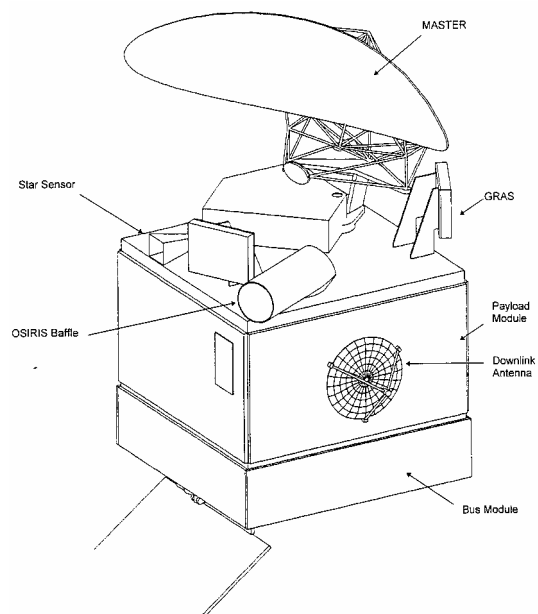

Figure 1 Reflector Antenna System of MASTER

## 2. Test Facilities

In recent decades, different types of facilities and test methods have been analyzed, developed and applied. Amongst these are Compact Antenna Test Ranges (CATR), based on the transformation of the spherical wave into a plane wave by a reflector system or by means of holography. Furthermore, near-field test facilities with planar, cylindrical or spherical probing are common. A CATR based on the principle of a hologram is also being developed [2,14].

At present, for the measurement of apertures larger in dimension than one meter, hologram CATRs have system inherent as well as manufacturing problems of the hologram itself [2], both requiring further development. The bandwidth of hologram CATRs is limited to 10 - 20 %, so that for each frequency band, new holograms must be designed, manufactured and installed in the facility. Therefore, the hologram CATR will not be treated in the context of this paper.

Reflector CATRs are already used for measuring large test objects at frequencies up to 200 GHz [3] as well as smaller objects at Terahertz frequencies [4]. The measurement accuracy in CATRs at high frequencies is driven mainly by the surface accuracy of collimating reflector(s). Because of the number of CATR designs, the topic of surface accuracy in this trade off must be limited. The same holds for near field test ranges. Thus for practical purposes, the trade off will be limited to the existing Astrium antenna test ranges: the Compensated Compact Range (CCR), model CCR 75/60, shown in Figure 2, and the Cylindrical Near-Field Test Facility (CNTF), model CNTF-8 of Astrium, shown in Figure 3.



**Figure 2** CCR 75/60 of Astrium GmbH (Germany)

The measurement accuracy of near-field ranges is driven by a number of factors such as positioning accuracy, cable flexing and coherent detection. Near field ranges are

usually used for measurements at frequencies up to 100 GHz.

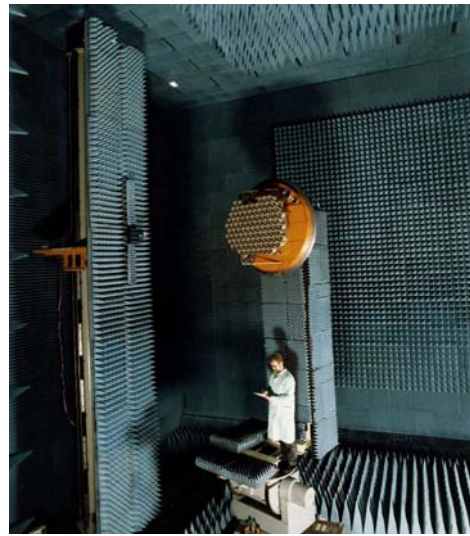

**Figure 3** CNTF-8 of Astrium GmbH (Germany)

Taking into account the existing CNTF-8 range characteristics, the feasibility of extending the operating frequency up to 500 GHz, must be considered as a function of required developments and expected accuracy.

## 3. MM-Wave Antenna Parameter

The tradeoff between the different antenna test facilities is driven by the application specific parameters. For limb sounder instruments with large antennas and operating at mm-wave frequencies, the following parameters are especially interesting:

- Pattern accuracy
- Gain accuracy
- Beam efficiency
- ACAP (Azimuthally Collapsed Antenna Pattern)

For the main beam region, the characteristic parameters are boresight directivity, half power beam width (HPBW), beam efficiency and beam pointing. For the region outside the main beam, side lobe levels may need to be verified and very low levels with respect to the main beam region. Beam efficiency requirements for limb sounders are usually very high, e.g. MASTER requires values up to 98 % for certain regions. In addition, the antenna gain exhibits high values of approximately 60 to 70 dBi. The dynamic range of the ACAP pattern should be known down to a level at least 45 dB below peak [5].

Significant errors in antenna pattern, gain, beam efficiency and ACAP are not only related to surface errors of the application specific antenna reflector. In CATR measure-

ments, the surface accuracy of the range reflectors is a factor as well. Theoretical investigations of surface errors with the software tool GRASP have already been performed [6]. In addition, errors in beam efficiency are a function of measurement truncation or and the dynamic range limitations of the measurement system.

#### 4. Measurement Errors

The main components of measurement errors in antenna test facilities, which affect the measurement accuracy, can be classified as follows:

- RF-System errors
- Positioning errors
- Mechanical errors of the collimating system (if applicable)
- Feed/Probe errors
- AUT (Antenna Under Test) errors
- Environment influences/errors
- Measurement procedure errors
- Computation accuracy errors

Each of the above mentioned categories can be subdivided into more detailed error contributions.

RF-System errors are mainly generated by non-linearity, drift and mismatch errors. Whereas drift is a significant problem for long measurement times as in near field tests, it is less of a problem in CATR tests.

The limited dynamic range of the near field facility's receiver affects the phase measurement accuracy. RF leakage and crosstalk can be minimized by high quality RF components and a well designed test setup. System phase errors in near-field ranges, caused by mechanical cable movements can be reduced by application of corrective measures such as the three cable method or the application of reflectivity measurements [7]. The remaining phase error results from temperature changes of the measurement equipment. A quantification of the error is given in [8] and an error level of 5 degrees can be achieved [9].

Positioning errors of the mechanical system for the feed/probe, as well as AUT positioning system, contain mainly the positioning inaccuracies of the turntable/scanner system and polarization errors. The finite alignment accuracy cannot be neglected in light of the very narrow beam widths being measured.

In near filed facilities, probe alignment with respect to the facility coordinate system is critical, as well as grid position inaccuracies, are important when measuring in the mm-wave range. The orientation inaccuracy can be expressed with the z-position error (z-direction equal to propagation direction assumed).

Highly accurate positioning systems can achieve minimum values down to some ten thousandth of a degree

for the wobble and drunkenness error of the azimuth position. In this case, the distance between turntable and AUT should be as short as possible. The probe positioning accuracy can be improved with special hard- and software correction measures, as Laser/PSD or interferometry systems [10] for position detection with subsequent correction.

Mechanical errors of the collimating system, is applicable when using a reflector CATR and are representative of the manufacturing accuracy. Also limited integration of the mechanical transformation system must be looked at. The surface accuracy of reflector(s) affects directly the accuracy of the plane wave field in the Quiet Zone. A quantitative analysis of the surface manufacturing inaccuracies and the subsequent effect on Quiet Zone field errors now follows.

Surface errors of CATR reflector systems can mainly be divided into:

- systematic backing structure errors
- randomly distributed long-distance surface errors
- short-distance milling track errors
- short-distance milling step errors

Random errors are a function of the limited milling machine accuracy for manufacturing large compact range reflectors. The CCR 75/60 reflector size is 5.6 m x 5.3 m for the subreflector and 7.5 m x 6.0 m for the main reflector. At Astrium GmbH, surface errors are measured for QA (Quality Assurance) requirements for all manufactured compact range reflectors. The short distance milling track and milling step errors are system inherent errors according to the milling process, as demonstrated in Figures 4 and 5. Error periodicities as well as maximum error levels of mechanical surface errors are shown in Table 1.

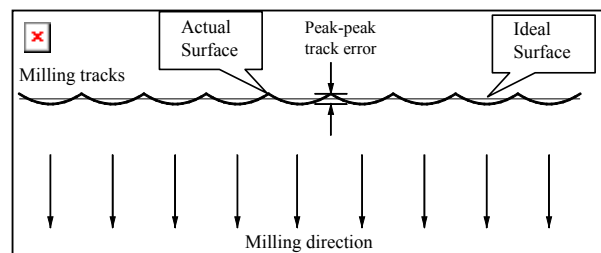
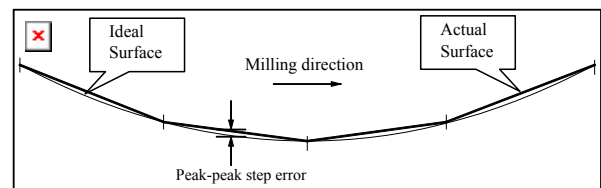

Figure 4 Short Distance Milling Track Errors



**Figure 5** Short Distance Milling Step Errors

Error	Error Periodicity	Error Level (Peak-Peak)
Random Error	-	30 $\mu\text{m}$
Track Error	26 mm	3 $\mu\text{m}$
Step Error	38 mm	2 $\mu\text{m}$

**Table 1** Error Periodicities and Maximum Error Levels for the CCR 75/60 Main Reflector

The superposition of the surface errors for a compact range reflector segment is shown in Figure 6. The distortions within the figure are greatly exaggerated to allow visualization (factor  $\approx 5000$ ).

Reflector alignment errors can be minimized by a highly sophisticated alignment procedure as given in [11].

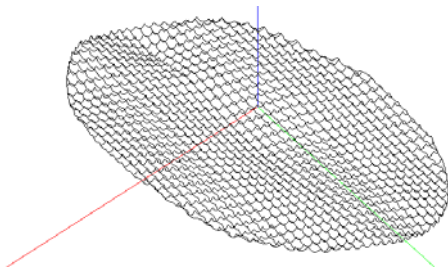

**Figure 6** Magnified Surface Errors of an Exemplary Considered CCR 75/60 Reflector Segment

Feed/probe errors are mainly caused by insufficient gain accuracy, pattern and polarization measurement, as well as port mismatch. The alignment errors can be minimized as referred to in [12]. The scattering cross section of the probe is more important in near-field test ranges where low gain horns are usually employed.

Similar to the feed/probe, equivalent AUT (Antenna Under Test) errors are present. In this case gain, pattern and polarization “errors” determine the AUT behaviour, which is intended to be measured. The large aperture sizes of the AUT lead to multiple reflections with the probe, the absorber area and reflecting objects. This predominant error source in near-field test facilities, calculated as given in [8], can significantly be reduced via averaging of different AUT z-position measurements. Also in CATRs, averaging can be applied for improvement of the measurement accuracy. AUT mismatch affects the antenna gain, if neglected within post-processing with network analyzer measurement data. Alignment errors can be minimized, as mentioned in [12].

Environmental errors consist of temperature, pressure and humidity variations during measurement campaigns. At Terahertz frequencies, water vapor and the dipole resonance of air molecules lead to additional attenuation

and influences the refractive index as well. In CATRs, mainly spatial variations, and in near-field test facilities, temporal variations as well, lead to measurement errors. Quantitative analyses for amplitude and phase influences are given in [13] and [14]. For both facilities, a correction of the errors can be performed via phase recording of a reference beam.

In addition to environmental errors, there are scattering effects, electromagnetic interference and signal leakage. Room scattering can be reduced sufficiently down to at least - 50 to - 60 dB in the frequency range between 1 and 100 GHz and down to - 40 dB above 100 GHz by using suitable absorbing material [14,15]. This error is dominant in CATRs. Electromagnetic interference can be neglected when using conductive chamber walls. Leakage exists in CATRs as the direct LOS (Line Of Sight) interference from the feed into the Quiet Zone and as reflection effects from the CATR reflector rim edges. With a properly designed and optimally positioned Astrium ‘baffle’, the direct leakage error can be reduced substantially. Other significant error contributions in CATRs are angular distortions from field incidence via different scattering objects into the quiet zone. According to the free-space path loss, these errors are less important in the frequency range above 200 GHz [14].

Measurement procedure errors are mainly caused by truncation, sampling point spacing and sampling rate degradations.

Truncation influences the measurement results of cylindrical near-field test facilities but are less severe for large AUTs in the higher frequency range, because of the concentrated field distribution in the spatial domain. A quantification of the truncation error is given in [14]. Nevertheless, a high sampling rate is necessary, which is a dominant factor for the measurement time. Sampling point spacing is determined by the sampling theorem and leads to aliasing errors.

Truncation and sampling influences are not evident in compact ranges according to the existent far-field condition and the positioning of the AUT within the Quiet Zone volume.

For improvement of the measurement accuracy of near-field test facilities, software corrections as described in [16] can be used. In CATRs, the AAPC method (Advanced Antenna Pattern Comparison) can be used, as described in [17].

Nowadays, computational errors can normally be neglected. In former times, these errors resulted out of slow data acquisition, limited instrument and drift correction software and non-applied probe compensation.

## 5. Facility Comparison

To quantify the measurement errors of different test facilities in order to receive comparative error values,

error budgets for significant antenna parameters are usually established. Due to the direct correlation of beam efficiency and gain errors, as well as ACAP and side lobe level errors, the main interests for the mentioned applications are pattern and gain budgets.

Table 2 shows the error budget for pattern and gain at 500 GHz for the Astrium CNTF-8, with possible improvement measures included. The improvements, also mentioned in Section 3, represent state-of-the-art correction measures, already used in highly accurate near-field test facilities. With the improvements implemented, an objective comparison and error analysis for the CNTF-8 and the CCR 75/60 can subsequently be performed.

Error contribution	Pattern error [dB] @ - 30 dB level	Gain error [dB] @ 0 dB level
Probe gain	0.00	0.20
Probe pattern	0.10	0.00
Probe polarization	0.05	0.00
Probe alignment	0.10	0.02
Probe z-position	1.43	0.12
Probe x-y-position	0.00	0.00
AUT alignment	0.00	0.00
Mismatch of AUT	0.00	0.05
Normalization constant	n.a.	0.10
Multiple reflections	0.14	0.05
Room scattering	0.09	0.05
Leakage and crosstalk	0.05	0.05
Truncation	0.15	0.05
Receiver nonlinearity	0.19	0.12
Receiver dynamic range	0.15	0.02
RF system phase	0.59	0.02
Aliasing	0.05	0.00
Random errors	0.05	0.00
<b>RSS Error level</b>	<b>1.56</b>	<b>0.30</b>

**Table 2** Error Budget for the Astrium CNTF-8 at 500 GHz With Possible Improvements Applied, Copolar Main Error Contributions ( $3\sigma$  values)

The resulting RSS pattern error for an assumed pattern level of - 30 dB can be given with max. 1.56 dB and the resulting RSS gain error for 0 dB gain level with max. 0.30 dB.

The error budget for the CCR 75/60 with improvements also implemented is shown in Table 3. According to different error sources for different angular ranges w.r.t. quiet zone (QZ) field incidence, error budget contributions for different incidence angles should be considered. Within the presented error budget, the angular distortions for the worst case are considered. The resulting pattern error exhibits max. 1.44 dB @ - 30 dB and 500 GHz. The maximum gain error at 500 GHz can be given with 0.31 dB @ 0 dB.

Error contribution	Pattern error [dB] @ - 30 dB level	Gain error [dB] @ 0 dB level
SGH gain	n.a.	0.20
Feed polarization	0.15	0.00
Feed alignment	0.00	0.00
AUT positioning	0.10	0.00
Mismatch of SGH	n.a.	0.05
Mismatch of AUT	0.03	0.05
Attenuator calibration	n.a.	0.10
Receiver accur. at SGH	n.a.	0.05
Receiver accur. at AUT	n.a.	0.05
Multiple reflections	0.15	0.05
Room scattering	0.25	0.01
Leakage and crosstalk	0.05	0.01
Angular distortions	max. 0.48	0.00
Receiver nonlinearity	0.30	0.00
Receiver dynamic range	0.07	0.00
Reflector surface	1.30	0.18
Serration and billboard	0.01	0.00
QZ taper on AUT	0.00	0.02
QZ ripple on SGH	n.a.	0.05
Other errors	0.05	0.03
<b>RSS Error level</b>	<b>1.44</b>	<b>0.31</b>

**Table 3** Error Budget for the Astrium CCR 75/60 at 500 GHz With Possible Improvements Applied, Copolar Main Error Contributions ( $3\sigma$  values)

Error values within the error budgets result out of error prediction, given in the literature [8], as well as extrapolated measurement data, determined in measurement campaigns within the 200 GHz frequency range [18]. Atmospheric influences were not considered in the present results.

## 6. Conclusions

For the measurement of large reflector antennas in the mm-wave range up to 500 GHz, as required by new ESA earth observation and science missions, test facilities have to meet a tight measurement accuracy. In principle, compact ranges and near-field test facilities are suggested, whereas hologram compact ranges are not applicable for large objects at present.

To select the most suitable test facility, a trade-off between the cylindrical near-field range CNTF-8 and Compensated Compact Range CCR 75/60 of Astrium was performed. With that aim, the measurement accuracy of both facilities was investigated and significant error contributions were analyzed. According to the severe influence of the reflector surface accuracy towards the measurement accuracy, detailed analyses were performed. With respect to limb sounder applications, especially

important antenna parameters were identified for a subsequent estimation of the influence of measurement errors towards the parameters.

The defined measurement errors were quantified in order to determine error budgets for pattern and gain measurements within an improved CNTF-8 and CCR 75/60. The budgets were also established within the ADMIRALS study of ESA/ESTEC for 203, 322, 406 and 503 GHz.

Comparative results for a state-of-the-art near-field and compact range test facility exhibit resulting error levels in the same order.

It should be mentioned, that for near-field systems, longer measurement time, the requirement for coherent detection and software postprocessing are factors to be considered. Similarly, the high procurement costs of very accurate compact range reflectors cannot be ignored while the demands on accurate optical and mechanical systems are greater for near field ranges than CATRs.

## 7. References

- [1] P. de Maagt, G. Crone, „(Sub)Millimetre Wave Antenna Technology for Upcoming ESA Missions“, *AP2000 Millennium Conference on Antennas & Propagation*, Davos, Switzerland, April 2000
- [2] T. Hirvonen, J. Ala-Laurinaho, A. Lehto, J. Tuovinen, A.V. Räsänen, „Feasibility of a Hologram CATR for Measuring Large MM- and SubMM-Wave Antennas“, *Proc. 20th ESTEC Antenna Workshop on MM-Wave Antenna Technology and Antenna Measurement*, Noordwijk, NL, June 1997
- [3] J. Habersack, W. Lindemer, H.-J. Steiner: „Sensor Measurements up to 200 GHz in the Compensated Compact Range with Broadband Transmit and Receive Modules“, *Proc. 19th AMTA*, Boston, USA, 1997
- [4] C. G. Parini, A. D. Olver, „The Use of a Reflector CATR for Antenna Measurements in the Region of One Terahertz“, *Proc. 20th ESTEC Antenna Workshop*, Noordwijk, NL, June 1997
- [5] G. Padovan, R. Jorgensen, P. de Maagt, „Millimeter Wave Antenna For Limb Sounding Application: Antenna Design, Focal Plane Assembly Breadboarding and Performances Assessment“, *Proc. 20th ESTEC Antenna Workshop*, Noordwijk, NL, June 1997
- [6] A. Quisse, P. de Maagt, D. Lamarre, G. Padovan, „MASTER Antenna Requirements: Some Investigations“, *Proc. 20th ESTEC Antenna Workshop*, Noordwijk, NL, June 1997
- [7] J. Tuovinen, A. Lehto, A. Räsänen, „A New Method for Correcting Phase Errors Caused by Flexing of Cables in Antenna Measurements“, *IEEE Trans. Antennas and Prop.*, Vol. 39, No. 6, 1991, pp. 859 – 861
- [8] A. C. Newell, „Error Analysis Techniques for Planar Near-Field Measurements“, *IEEE Trans. Antennas and Prop.*, Vol. 36, No. 6, 1988, pp. 754 – 768
- [9] T. Sehm, A. Lehto, J. Tuovinen, A.V. Räsänen, „Planar Near-Field Scanning Measurements of Large Antennas at Terahertz Frequencies“, *Proc. 20th ESTEC Antenna Workshop*, Noordwijk, NL, June 1997
- [10] D. Slater, „A 550 GHz Near-Field Antenna Measurement System for the NASA Submillimeter Wave Astronomy Satellite“, *Proc. 16th AMTA*, Long Beach, USA, 1994
- [11] H. Kress, J. Habersack, R. Mayer, „Optically and RF Measured Facility Boresight in Compensated Compact Ranges“, *Proc. 21th AMTA*, Monterey, USA, October 1999
- [12] H. Kress, J. Habersack, S. Paus, „Alignment Concept for Spacecraft Antennas in State of the Art Test Facilities“, *Proc. 20th AMTA*, Montreal, Canada, 1998
- [13] D. H. Martin, „The Need for Control of the Atmosphere in a Terahertz Antenna Measurement Range“, *Proc. 20th ESTEC Antenna Workshop*, Noordwijk, NL, June 1997
- [14] MMWAVE Antenna Testing Techniques – Phase 2 MAAS Report 304, Issue No. 2, December 1996
- [15] R. J. Wylde, D. H. Martin, „RAM for Terahertz Antenna Measurement Range“, *Proc. 20th ESTEC Antenna Workshop*, Noordwijk, NL, June 1997
- [16] R. C. Wittmann, B. K. Alpert, M. H. Francis, „Planar Near-Field Measurements Using Nonideal Measurement Points“, *Proc. 22nd ESTEC Antenna Workshop on Antenna Measurements*, Noordwijk, NL, May 1999
- [17] J. van Norel, J. Habersack, M Boumans, „The Use of Pattern Comparison Methods for Satellite Testing“, *Proc. 18th AMTA*, Seattle, USA, 1996
- [18] J. Habersack, „MAS Test Report for the Main Phase“, MBB, Ottobrunn, Germany, 1989